

Linear diffusers

CONTINUOUS SLOT DIFFUSER

introduction

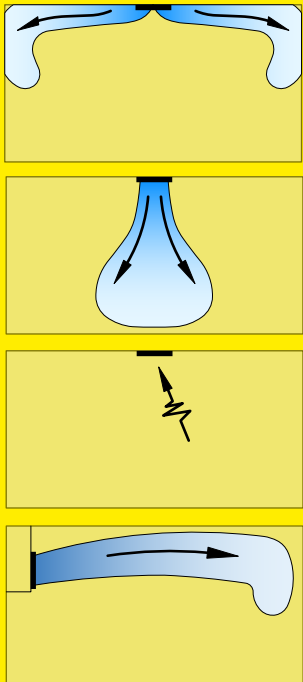

The Flowline diffuser has been specifically developed to meet requirements for an aerodynamically efficient continuous slot air distribution system. The unique design of the deflection tube produces both low noise and low pressure losses, making it suitable for use with variable air volume, fan coil or induction systems.

Adjustment of the tubes can be easily carried out from the diffuser face to give control of the air direction and also the discharge velocity. This latter feature is particularly useful with variable air volume systems, allowing an optimum jet velocity to be set to maintain air movement at low air flow rates.

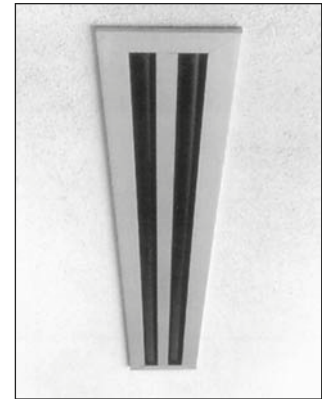

The Flowline system is completely modular, offering single section lengths up to 3m, in maximum widths of 8 slot.

The use of alignment plates and pins assist installation, whilst pre formed corner sections can be specified to any angle, eliminating the need for site trimming.

Dummy lengths are available where non active sections are required to maintain architectural continuity.

type

FLOWLINE Flanged, Recessed and Plaster Frame.

control

Control options include plenum mounted opposed blade dampers (OB) or spigot mounted flap dampers (FDQ Quadrant operated or FDC Cord operated).

options

A full range of plenums are available to suit a variety of installation conditions. See **PART H** for details.

fixings

We offer 2 types of fixing method. The first being the yoke strap fixing method which is offered as standard, providing ease of installation when used with Brooke air plenums. Installation details are shown on the installation page 12.

The second fixing method is via screw through plenum flange. This is used on plaster in frame. Again, further details regarding fixing can be found on the installation page.

finish

The standard finish is satin anodised frame and 'T' sections with matt black tubes. A wide range of paint finishes are also available in BS or RAL colours, as detailed in **PART I**. The following designations should be used when specifying the required finish:

- A = Satin anodised frame with black tubes.
- B = Specified frame colour with black tubes.
- C = Specified frame colour including tubes.

Linear diffusers

CONTINUOUS SLOT DIFFUSER

design features

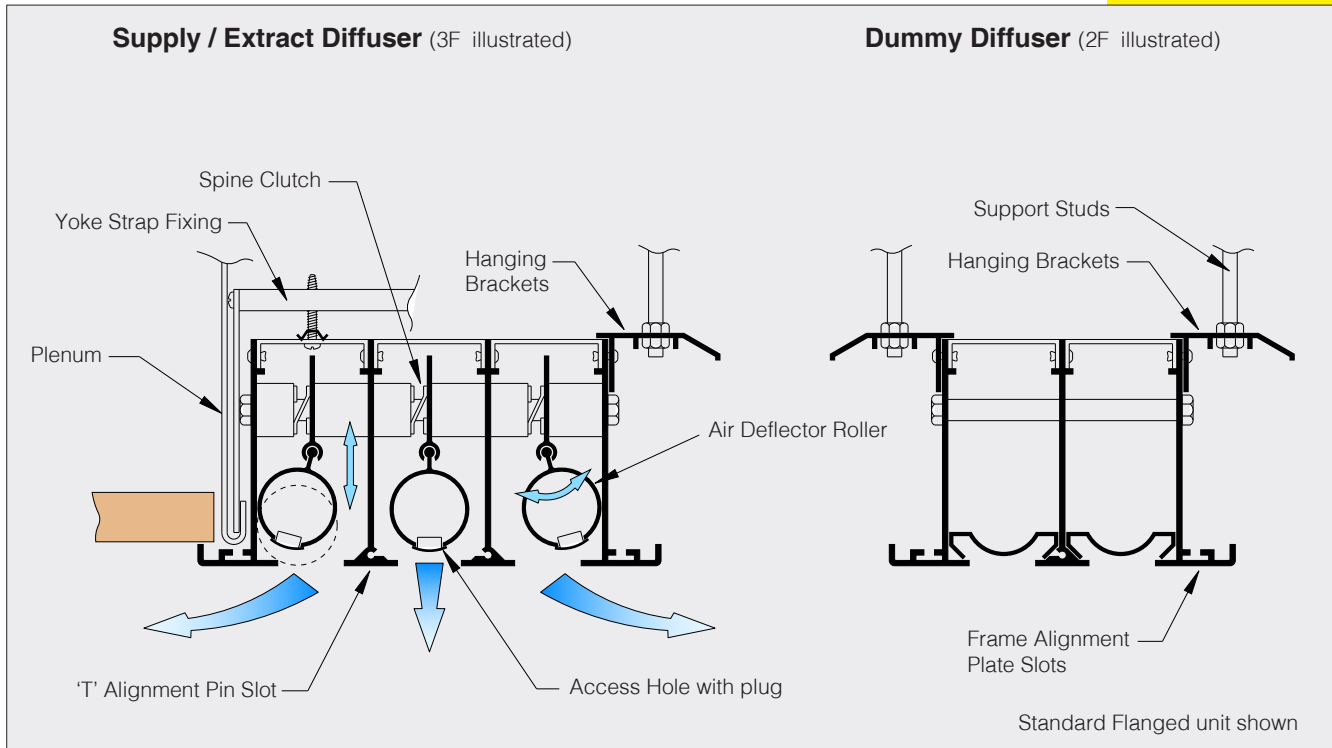

Lateral and vertical adjustment of the deflection tubes provides full directional jet control and discharge velocity regulation. The aerodynamic profile of the tube also gives the Flowline diffuser a wide dynamic flow range, making it particularly suitable for variable air volume application.

Typically, ceiling attachment can be maintained under cooling conditions with air flow rates as low as 10 l/s/m per slot.

curved options

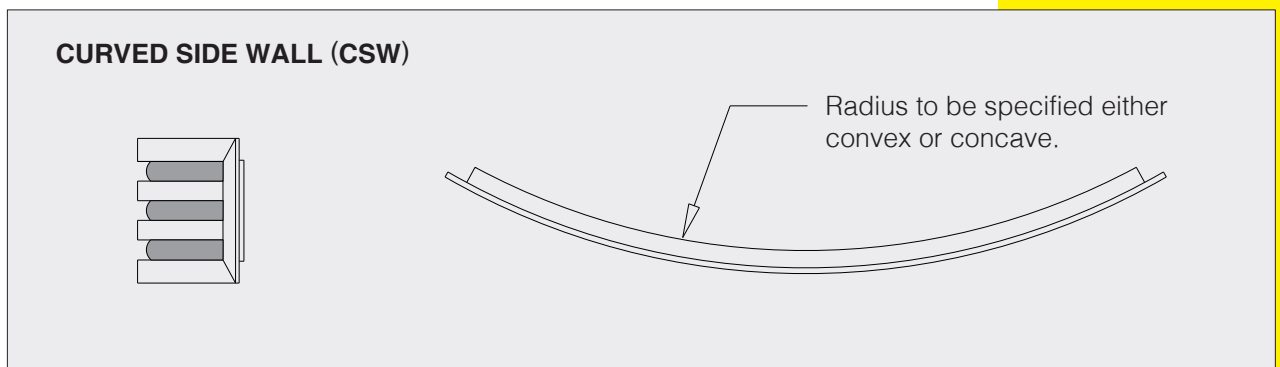
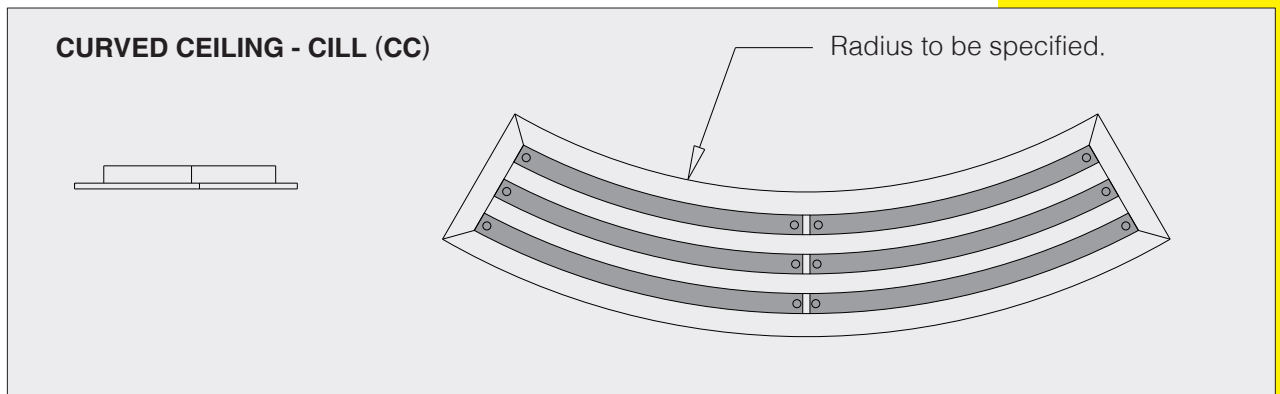

Linear diffusers

DIMENSIONS

dimensions

TYPE - 3F

(Flanged)

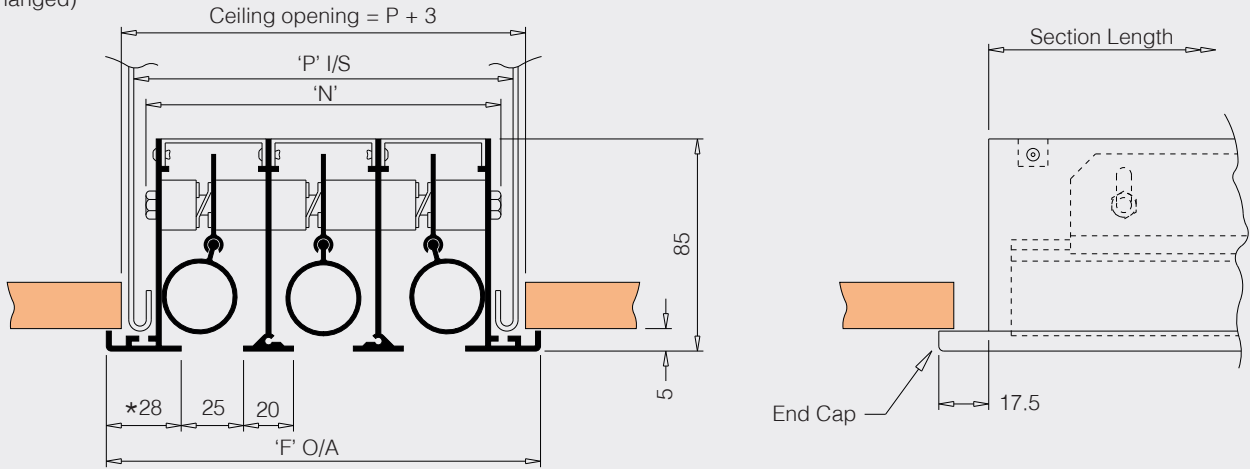

* ~~Optional flange widths of 22mm and 33mm are also available. Subtract 12mm or Add 10mm from the overall flange dimension respectively.~~

	NUMBER OF SLOTS							
	1F	2F	3F	4F	5F	6F	7F	8F
'N' o/a NECK	55.5	101.5	147.5	194	240	286	331	378
'P' i/s PLENUM	70	116	162	208	254	300	346	392
'F' o/a FLANGE	83	129	175	221	267	313	359	406

Note: inside Plenum length add 6mm when using end caps.

TYPE - R/3F

(Recessed)

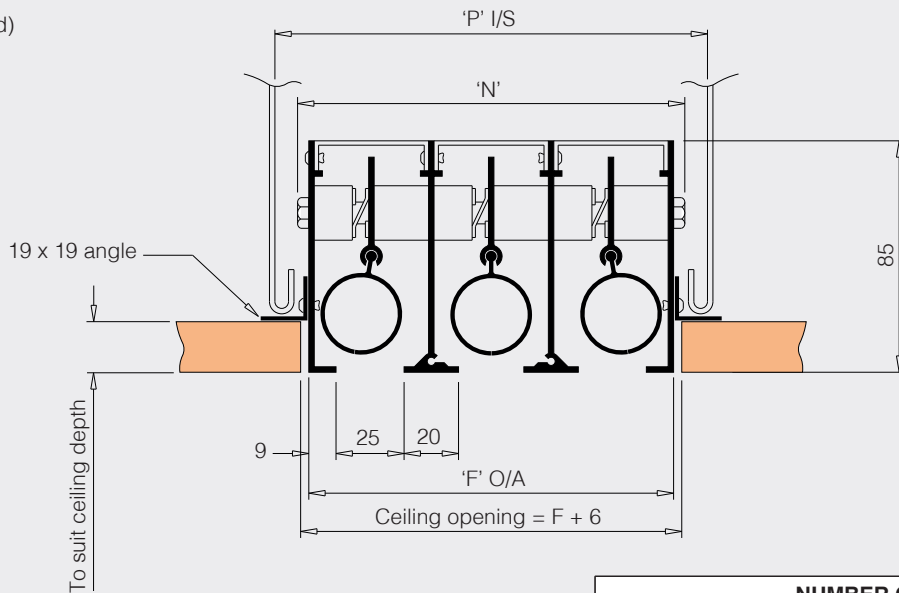

	NUMBER OF SLOTS							
	R/1F	R/2F	R/3F	R/4F	R/5F	R/6F	R/7F	R/8F
'N' o/a NECK	55.5	101.5	147.5	194	240	286	331	378
'P' i/s PLENUM	70	116	162	208	254	300	346	392
'F' o/a FLANGE	48	94	140	186	232	278	324	370

Note: inside Plenum length add 10mm when using end caps.

Linear diffusers

DIMENSIONS / ORDERING DESIGNATIONS

dimensions

TYPE - 3F/RPF

(Plaster in frame)

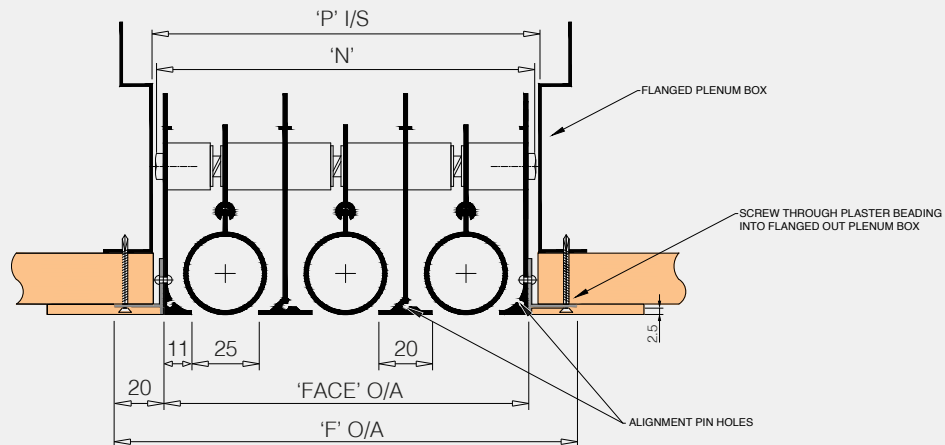

	NUMBER OF SLOTS								
	RPF/1F	RPF/2F	RPF/3F	RPF/4F	RPF/5F	RPF/6F	RPF/7F	RPF/8F	
'N' o/a NECK	55.5	101.5	147.5	194	240	286	331	378	FACE +8
'P' i/s PLENUM	62	108	154	200	246	292	337	384	NECK +8
'F' o/a RPF FLANGE	90	136	182	228	274	320	366	412	FACE +42
FACE	48	94	140	186	232	278	324	370	

Note: inside Plenum length add 10mm when using end caps.
Nominal ceiling opening = Neck+8

ordering designations

When ordering linear sections, state the number of slots required, the section length and the finish designation code. Diffusers are supplied as standard with 28mm flanges. Requirements for the optional flange widths of 22mm and 33mm should be specified separately.

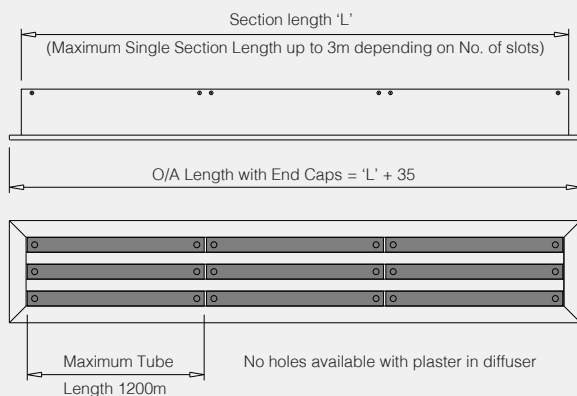

For dummy sections, add the specification D to the type, ie 3FD.

Examples :

type	end option	finish	length	quantity
3F	/ ENDS	/ A	/ 1500	/ 6
type	end option	finish	length	quantity
3F/RPF	/ ENDS	/ A	/ 1500	/ 6

When ordering corner sections, state the number of slots required, the inside lengths A and B, the angle and the finish designation code. Note: dimensions A and B should be based on the reflected ceiling plan.

Corners are normally supplied as non active sections. Other angles available.

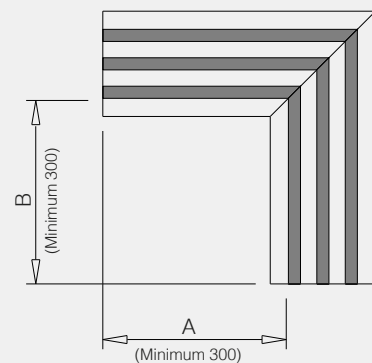

type	angle	finish	length (A x B)	quantity
3F	/ 90°	/ A	/ 300 x 300	/ 6

Linear diffusers

INSTALLATION

installation

When using the yoke strap fixing technique, the plenum is normally installed as a first fix item, with the hem edge levelled to the ceiling grid system. From there, the diffuser yoke straps can be inserted into the plenum, working from one end and butting the section lengths together.

Once the yoke straps are secured, the screws can be tightened to level the diffuser to the ceiling.

STANDARD INSTALLATION WITH YOKE FIXING

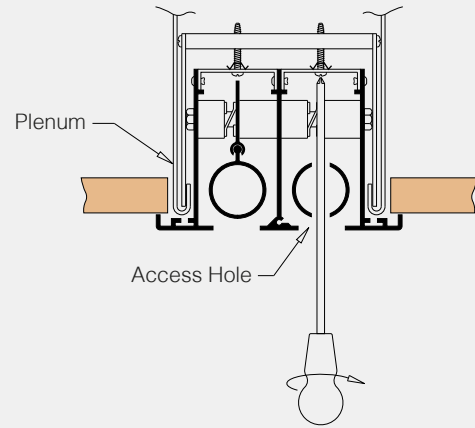
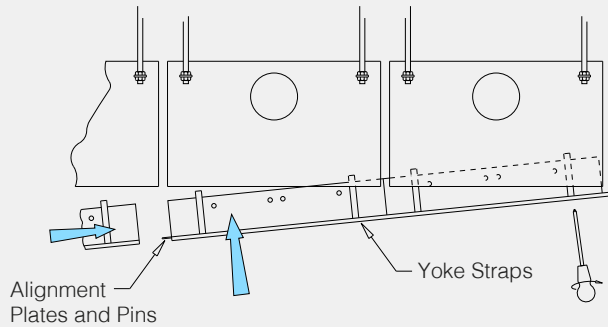

Full installation instructions are provided with the diffusers.

When using the plaster in frame fixing method the plenum should already be installed in its correct position behind the plasterboard. The grille is then positioned into the aperture with the plaster in flange aligned with the flange of the plenum on the other side of the plaster. From this position, the flanges must be screwed together with the screw passing through the plaster in flange, through the plasterboard wall and then through the plenum flange securing it in place. The plaster in flange can then be skimmed over so only the grille face is visible. Skrim tape / PVC agent to be used before plaster is applied.

FLOWLINE INSTALLATION DIAGRAM FOR PLASTER IN FRAME

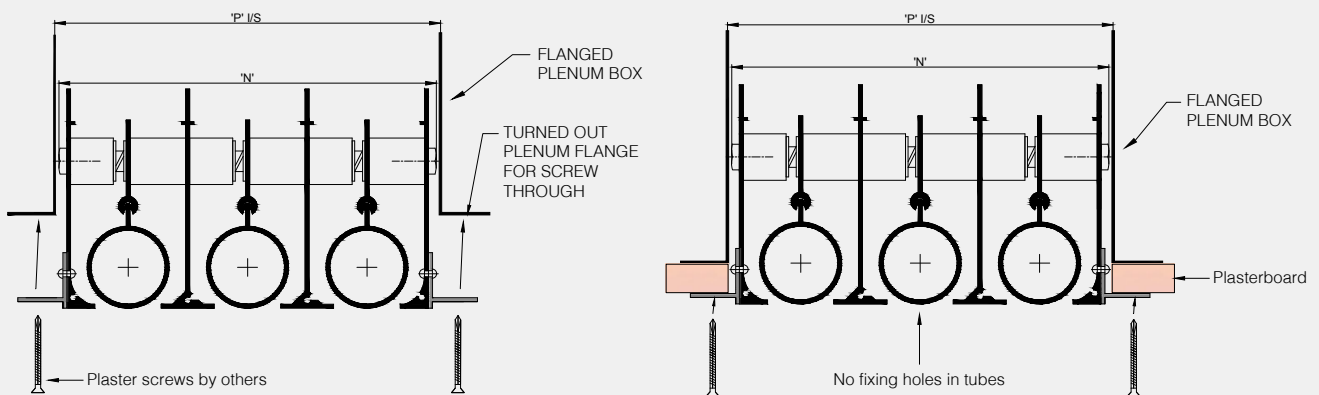

Linear diffusers

PERFORMANCE DATA

basis of data

The following tabulated data is based on a 1.2m length of diffuser with the pattern control tubes fully recessed into the frame. Correction factors should be applied to the noise and throw data for continuous lengths. (See table 1 on page 14.)

projection

Projection data is based on a vertical free jet at a heating differential of 10°C and represents the point at which the jet has fully retarded. Correction factors can be applied for other heating differentials, as detailed in table 2 on page 14.

throws

Maximum and minimum throws are based on jet terminal velocities (V_t) of 0.25 and 0.75m/s respectively and correspond to average room air velocities (V_r) of 0.1 and 0.25m/s with a cooling differential of 11°C and a room height of 2.7m. Where the application height differs from this, throw selections should be adjusted accordingly; that is, increasing the throw by 1m for every 1m increase in height.

noise levels

Noise data is based on one or two way horizontal throw configurations and is expressed in terms of NR level with a room absorption factor of 8dB.

When used in projection mode the noise levels are reduced by NR3.

			AIR FLOW RATE (l/s/m)									
			20	40	60	80	100	120	140	160	180	200
1F	THROW (m)	MIN	0.7	1.5	2.3	3.0	4.0	4.7				
		MAX	2.0	3.4	4.7	5.8	7.0	8.0				
	PROJECTION (m)			1.5	2.5	3.5	5.0	6.5				
	Ps (Pa)			1.5	5	12	20	31	45			
NR LEVEL				12	23	31	38	43				
2F	THROW (m)	MIN			1.6	2.2	2.7	3.3	4.0	4.5	5.2	5.6
		MAX			3.0	4.0	5.0	5.8	6.8	7.5	8.6	9.4
	PROJECTION (m)				1.5	2.1	2.7	3.4	4.3	5.1	6.0	7.0
	Ps (Pa)				3	5	8	11	15	20	26	31
NR LEVEL					15	22	27	31	35	38	41	

			AIR FLOW RATE (l/s/m)									
			100	125	150	175	200	225	250	275	300	350
3F	THROW (m)	MIN	1.5	2.5	3.4	3.7	4.8	5.4	6.2	6.7		
		MAX	3.2	4.5	6.0	7.5	8.7	9.7	10.7	11.5		
	PROJECTION (m)		2.0	2.7	3.3	4.0	4.8	5.7	6.5	7.5		
	Ps (Pa)		4	6	8	11	14	18	22	26		
NR LEVEL			18	24	28	32	35	39	42			
4F	THROW (m)	MIN		2.0	2.8	3.5	4.2	5.0	5.5	6.2	6.7	7.8
		MAX		3.5	4.7	6.0	7.2	8.3	9.5	10.5	11.4	13.0
	PROJECTION (m)			2.0	2.6	3.1	3.8	4.4	5.0	5.7	6.5	7.8
	Ps (Pa)			3	5	6	8	10	12	15	18	24
NR LEVEL				15	20	23	27	31	33	36	41	

Linear diffusers

PERFORMANCE DATA

			AIR FLOW RATE (l/s/m)									
			200	225	250	275	300	325	350	375	400	450
5F	THROW (m)	MIN	3.5	4.0	4.7	5.3	6.0	6.5	7.2	7.8	8.3	9.4
		MAX	6.1	7.0	8.0	9.0	10.0	10.7	11.5	12.5	13.0	14.0
	PROJECTION (m)	3.2	3.7	4.2	4.8	5.4	6.0	6.6	7.2	8.0	9.2	
	Ps (Pa)	5	7	8	10	12	13	16	18	20	25	
	NR LEVEL	18	22	25	28	31	33	36	38	40	43	
6F	THROW (m)	MIN	2.8	3.4	4.0	4.5	5.2	5.7	6.2	6.8	7.4	8.4
		MAX	5.4	6.2	7.0	8.0	8.8	9.7	10.4	11.2	12.0	13.4
	PROJECTION (m)	2.7	3.2	3.6	4.1	4.6	5.2	5.7	6.2	6.8	7.8	
	Ps (Pa)	4	5	6	7	8	9	11	12	14	18	
	NR LEVEL	15	18	22	25	27	30	32	34	35	39	

			AIR FLOW RATE (l/s/m)									
			275	300	325	350	375	400	450	500	550	600
7F	THROW (m)	MIN	4.0	4.5	5.0	5.6	6.0	6.6	7.6	8.6	9.3	
		MAX	7.3	8.0	9.0	9.7	10.4	11.0	12.5	13.5	14.5	
	PROJECTION (m)	3.6	4.1	4.5	5.0	5.6	6.0	7.0	8.0	9.4	10	
	Ps (Pa)	5	6	7	8	10	11	14	17	20		
	NR LEVEL	20	22	25	27	29	31	35	38	41		
8F	THROW (m)	MIN	3.4	3.9	4.4	5.0	5.4	5.9	6.8	7.8	8.6	9.3
		MAX	6.4	7.0	8.0	8.6	9.4	10.0	11.2	12.4	13.2	14.0
	PROJECTION (m)	3.2	3.6	4.0	4.3	4.8	5.2	6.0	7.0	8.1	9.1	
	Ps (Pa)	4	5	5	6	7	8	10	12	15	18	
	NR LEVEL	15	18	20	23	25	27	31	34	37	40	

Length correction factors

table 1

	ACTIVE DIFFUSER LENGTH (m)					
	0.5	1.0	1.2	2.0	2.5	3.0
Throw/Projection factor	0.7	0.8	1.0	1.1	1.25	1.5
NR addition	-4	-1	0	+2	+3	+5

Temperature correction factors

table 2

	TEMPERATURE DIFFERENTIAL (°C)					
	-10	0	+5	+10	+15	+20
Throw factor	1.0	1.1	1.15	1.2		
Projection factor	1.6	1.25	1.15	1.0	0.73	0.62

Exhaust correction factors

table 3

NR correction	+5
Pressure loss factor	1.3